

**ASSEMBLY & INSTALLATION NOTES****JUBU upgrade intercooler tank (JU00197PRD)***for Exige 390 / 410 / 420 / 430*

**Please follow the instructions in this manual for a proper assembly & installation of the JUBU upgrade intercooler tank for Exige 390, 410, 420 and 430.**

*Please find in this document:*

- 1. PART LIST**
- 2. ASSEMBLY & INSTALLATION NOTES**

**1. PART LIST for product JU00197PRD**

#	ITEM	ART-NO.	UNITS
1	Upgrade intercooler tank and bracket	JU00874ART	1
2	Head cap screw DIN912 M8x20	-	2
3	Washer M8	-	2
4	Hose elbow Ø19 90°	JU00276	3
5	Hose elbow Ø19 90° long	JU00743	1
6	CNC connector Ø19	JU00255	3
7	Spring band clamp Ø27	JU01607	12



Fig 1: Scope of delivery

## 2. ASSEMBLY & INSTALLATION NOTES

Level of difficulty: **MEDIUM**

Required time: **3h - 4h** (depending on experience & available tools & skills)

1. The OEM intercooler tank must be removed.
2. The JUBU upgrade intercooler tank and bracket (1) is screwed onto the drivetrain unit as shown in *Fig. 2* and *Fig. 3*. Use the OEM screws and 2x M8x20 and head cap screws (2) including M8 washers (3). The M6 screw is tightened with 10Nm, the M8 screws (2) with 25Nm and the M10 screw with 50Nm. All screws are fixed with *LOCTITE 243* locking lacquer.

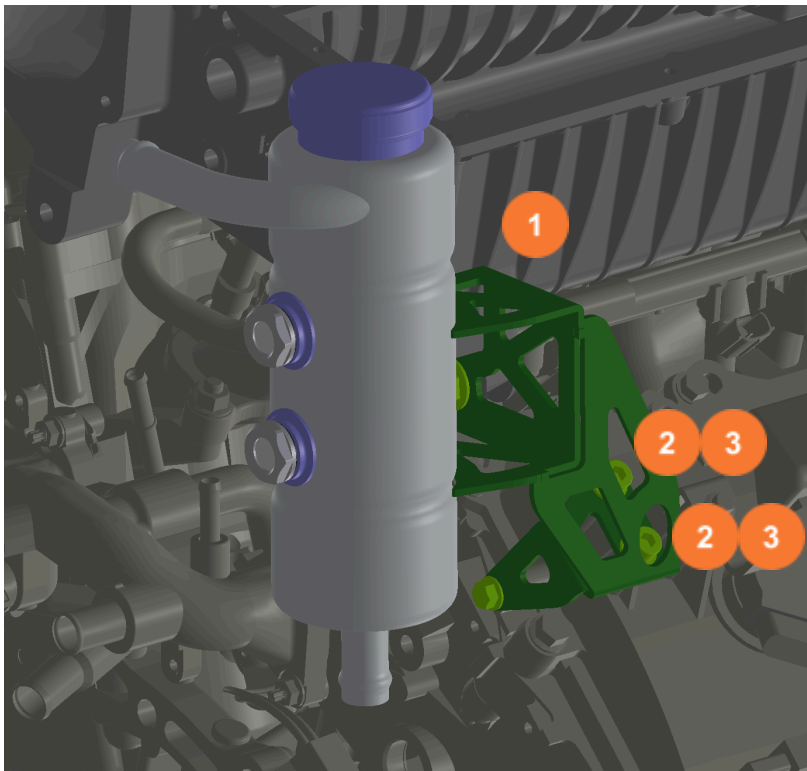

Fig 2. JUBU upgrade intercooler tank bolted onto the drivetrain unit

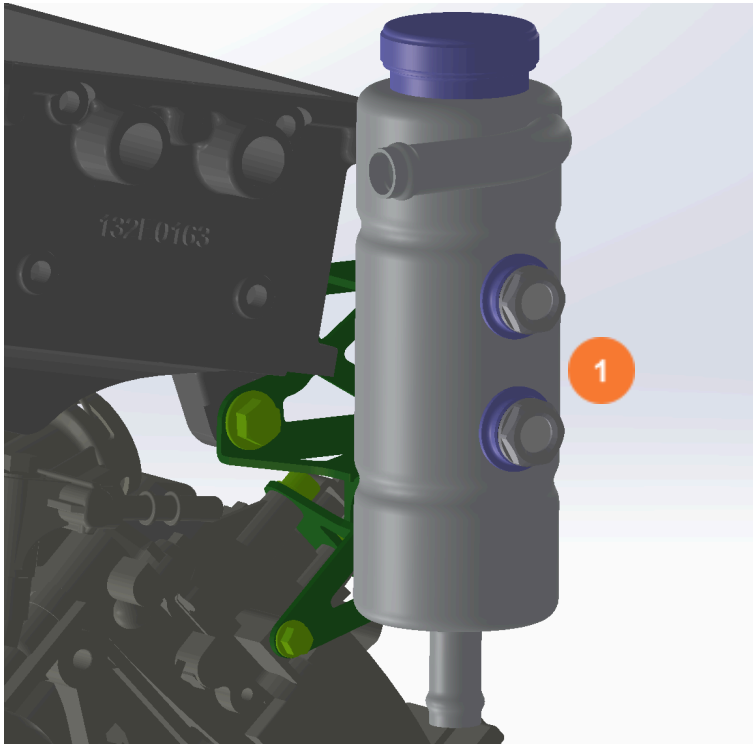

Fig 3. JUBU upgrade intercooler tank bolted onto the drivetrain unit

3. The JUBU upgrade intercooler tank (1) is connected to the supercharger, the intercooler pump and the OEM hoses as shown in *Fig. 4*, *Fig. 5* and *Fig. 6*. Use the 3 pcs. hose elbows  $\text{Ø}19\ 90^\circ$  (4), 1 pcs hose elbow  $\text{Ø}19\ 90^\circ$  extra long (5), 3 pcs  $\text{Ø}19$  CNC connector (6) and 12 pcs spring band clamps  $\text{Ø}27$  (7).

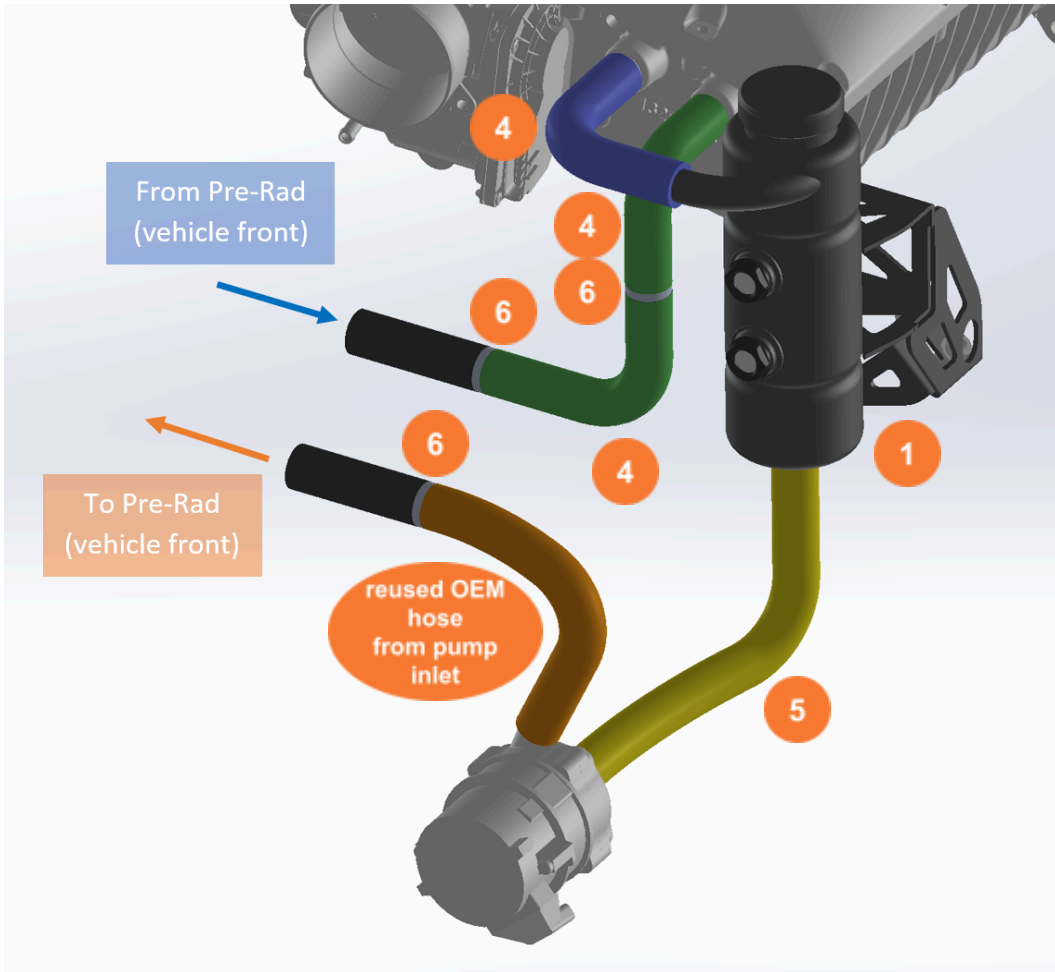

Fig. 4 Scheme for the tubing for the upgrade intercooler tank.

**⚠ NOTE:** Intercooler pump exit: The OEM hose from the pump inlet is reused.

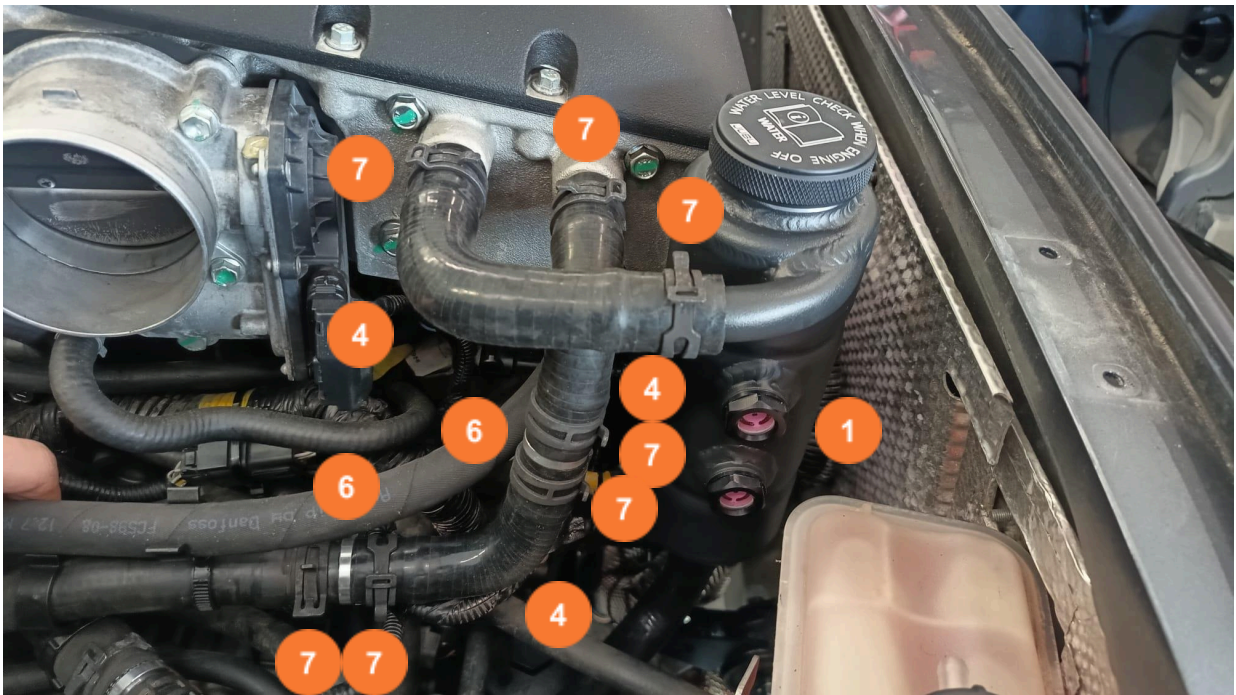

Fig. 5 Connecting the JUBU intercooler tank to the supercharger hose and the OEM hose

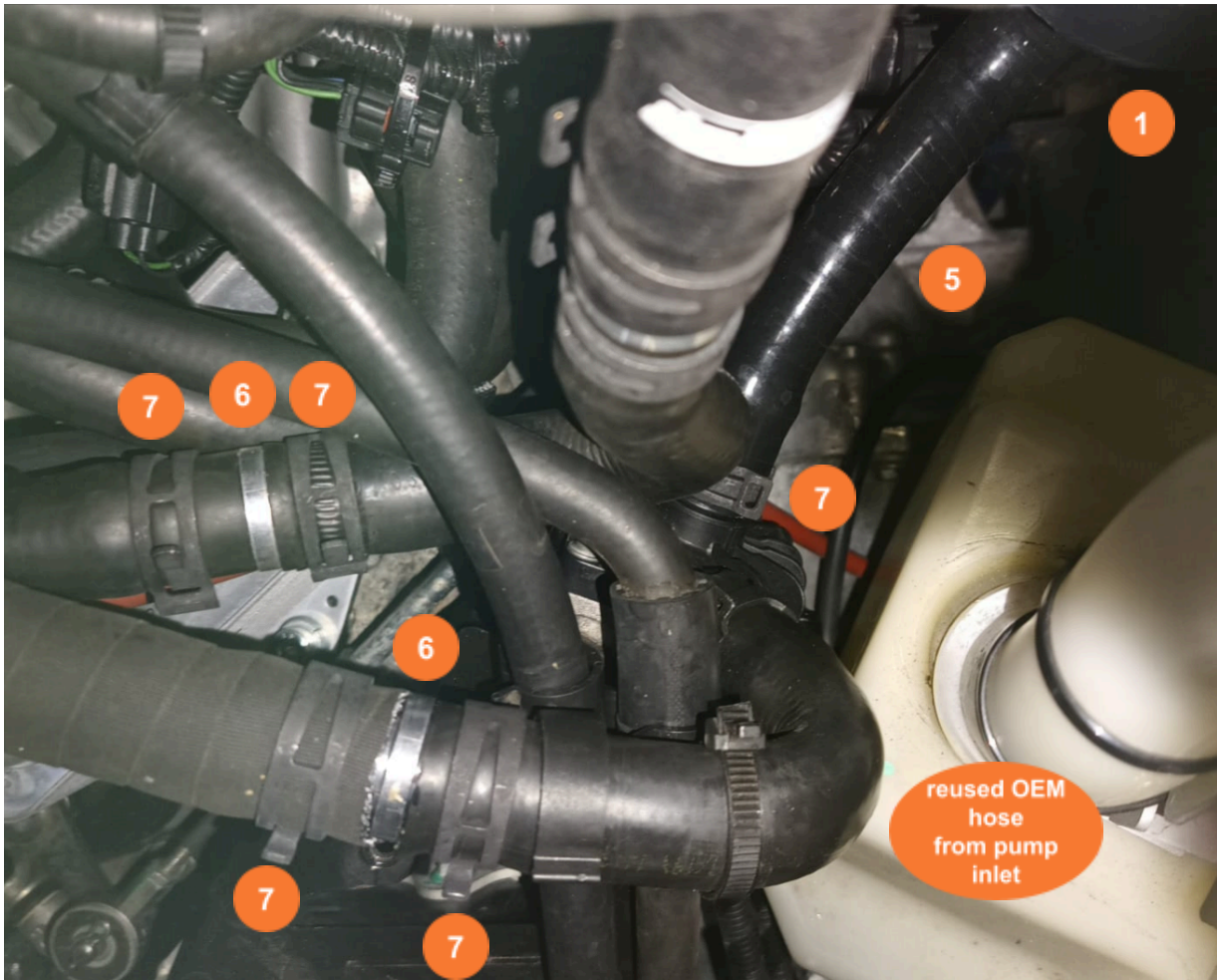

Fig. 6 Connecting the JUBU intercooler tank to the intercooler pump and the OEM hose

4. If the car is running the lower sight glass should be full and the upper one should be empty/clear.
5. The system needs to be checked carefully for leakages.

\*\*\*\*\*

If you have any questions or need additional information, please contact us by email:

[info@jubu-performance.com](mailto:info@jubu-performance.com)

**JUBU Performance GmbH**

Saxenegg 3a, 4323 Münzbach, AUSTRIA